



# 产品规格书

## SPECIFICATION

客户名称 **Customer:** \_\_\_\_\_

样品型号 **Model:**           BH1311-0312J9W\*\*-KV4          

客户料号 **P/N:** \_\_\_\_\_

打印日期 **Print Date:** \_\_\_\_\_

供应商确认			客户确认		
Manufacturer confirmation			Customer confirmation		
制作 Formulate	审核 Audit	批准 Approval	测试 Tester	审核 Audit	批准 Approval

用“芯”创造健康舒适、智慧人文的照明环境

**High quality COB lighting ---Create a healthy, comfortable, intelligent and humanistic lighting environment**

\*规格书如有变更恕不另行通知;

\*规格书最终解释权归佛山市中昊光电科技有限公司所有;

\*Specifications are subject to change without prior notice;

\*Foshan Evercore Optoelectronic Technology Co., Ltd. has the right to interpret the specifications

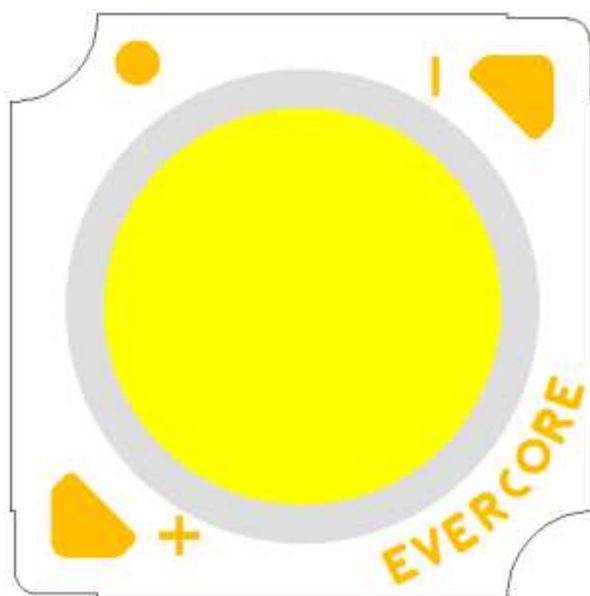

## 目录 Catalogue

➤ 应用范围 Application .....	3
➤ 产品尺寸 Product dimensions.....	3
➤ 产品特点 Product characteristics .....	3
➤ 光电参数 Basic parameters .....	4
➤ 极限参数 Limit parameters .....	4
➤ 特性曲线 Reliability test curve .....	5
➤ 分光标准 White bins on CIE .....	6
➤ 包装说明 Package and label illustration .....	7
➤ 产品编码 Coding rules .....	8
➤ 测试项目 Test items .....	8
➤ 注意事项 Announcements .....	9

## ➤ 应用范围 Application

导轨灯 Tracking Light	射灯 Spot Light	帕灯 Par Light	球泡 Bulb Light	筒灯 Down Light
				

## ➤ 产品尺寸 Product dimensions

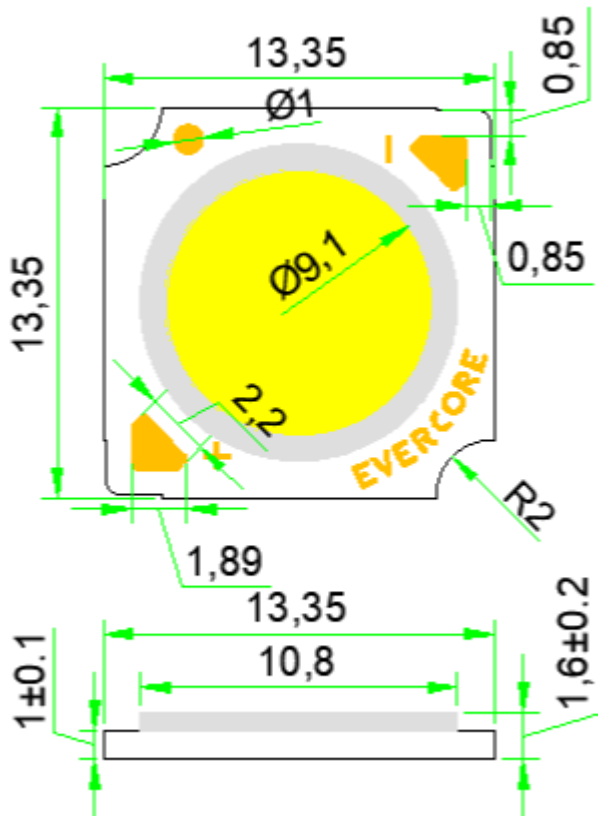

等效电路（3 并 12 串）  
Equivalent-circuit (3 parallels 12 series)

\*尺寸单位：mm，无特殊说明，公差为±0.2mm

Unit : mm, tolerance±0.2 unless stated otherwise

## ➤ 产品特点 Product characteristics

- 1) 光色一致性好、高亮度、高光效； Good consistency of light color, high flux , high efficiency;
- 2) 低热阻，热稳定性好； Low thermal resistance, good thermal stability;
- 3) 兼容性强，易于安装使用； Strong compatibility, easy to install and use;
- 4) 产品可靠性高； High reliability;
- 5) 符合 LM-80、RoHS 标准； LM-80 Certified and applied with RoHS standard
- 6) 按 ANSI 标准分光； ANSI standards

➤ 光电参数 Basic parameters (T<sub>J</sub>=85°C)

产品型号 Model	色温 CCT	Ra	R9	光通量 Luminous flux(LM)			Typ. Lumens (LM/W)	Typ. current 电流(mA)	thermal resistance R <sub>j</sub> (°C/W)
		Min.	Min.	T <sub>J</sub> =85°C		T <sub>C</sub> =25°C			
				Min.	Typ.	Typ.			
BH1311-0312J9W27G-KV4	2700K	80	0	1190	1294	1437	141	270	0.68
BH1311-0312J9W30G-KV4	3000K	80	0	1253	1362	1513	148	270	0.68
BH1311-0312J9W35G-KV4	3500K	80	0	1290	1403	1558	153	270	0.68
BH1311-0312J9W40G-KV4	4000K	80	0	1315	1430	1589	156	270	0.68
BH1311-0312J9W50G-KV4	5000K	80	0	1309	1423	1581	155	270	0.68
BH1311-0312J9W57G-KV4	5700K	80	0	1303	1416	1574	154	270	0.68
BH1311-0312J9W65G-KV4	6500K	80	0	1297	1409	1566	154	270	0.68
BH1311-0312J9W27H-KV4	2700K	90	50	1001	1088	1209	119	270	0.68
BH1311-0312J9W30H-KV4	3000K	90	50	1065	1157	1286	126	270	0.68
BH1311-0312J9W35H-KV4	3500K	90	50	1107	1204	1337	131	270	0.68
BH1311-0312J9W40H-KV4	4000K	90	50	1139	1238	1376	135	270	0.68
BH1311-0312J9W50H-KV4	5000K	90	50	1150	1250	1389	136	270	0.68
BH1311-0312J9W57H-KV4	5700K	90	50	1161	1262	1402	137	270	0.68
BH1311-0312J9W65H-KV4	6500K	90	50	1155	1256	1395	137	270	0.68

Note: device tolerance 1)光通量±7% for luminous flux:±7% 2) 电压±5% Voltage±5%  
3)色坐标: ±0.002 device tolerance for color coordinate:±0.002 4) Ra/R9±2

➤ 极限参数 Limit parameters (T<sub>a</sub>=25°C)

参数 Parameters	符号 Symbol	Min	Typ	Max	单位 Unit
正向电压 Forward V(T <sub>J</sub> =85°C)	V <sub>f</sub>	32	34	38	V
正向电流 Forward A	I <sub>f</sub>	-	270	690	mA
功率 Power (T <sub>J</sub> =85°C)	P <sub>i</sub>	-	9	26.22	W
结温 Junction Temp	T <sub>j</sub>	-	105	125	°C
静电 Attractions(HBM)	-	-	-	8000	V
出光角度 View Angle	2θ <sub>1/2</sub>	-	120	-	degrees
工作温度 Operation Temperature	T <sub>op</sub>	-20	-	+85	°C
储存温度 Storage Temperature	T <sub>st</sub>	-40	-	+100	°C
焊接温度 welding temperature	T <sub>sol</sub>	-	-	350	°C

\*T<sub>a</sub>=25°C 使用时, T<sub>c</sub>≤85°C; 实际使用环境下, 硅胶面温度≤130°C;

\*T<sub>a</sub>=25°C Bonding pad T<sub>c</sub> < 85°C. In actual condition, silica gel surface temperature of ≤130°C

## ➤ 特性曲线 Reliability test curve

1、温度与光通量曲线图 Temperature Vs Lumen

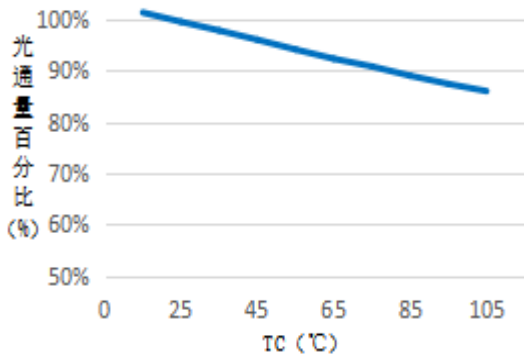

2、Tc-If 曲线图 TC VS IF curve

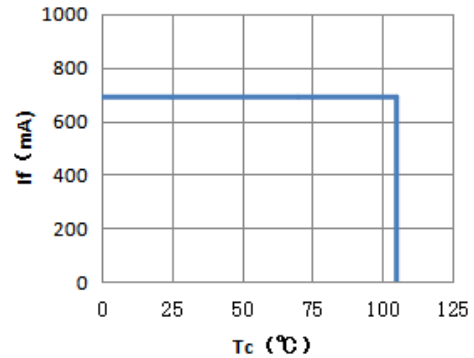

3、电流与光通量曲线图 Current Vs Lumen

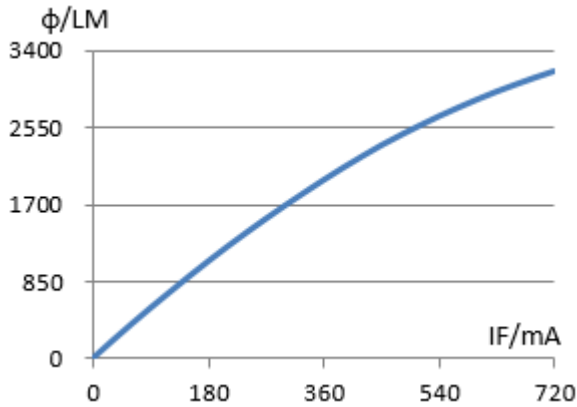

4、伏安特性曲线 Voltage Vs Current

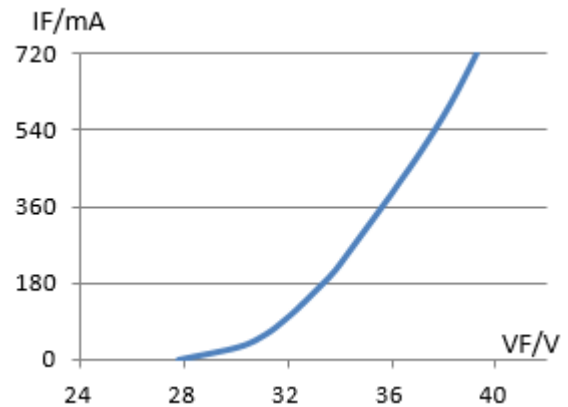

5、相对光谱曲线图 Relative spectral curve

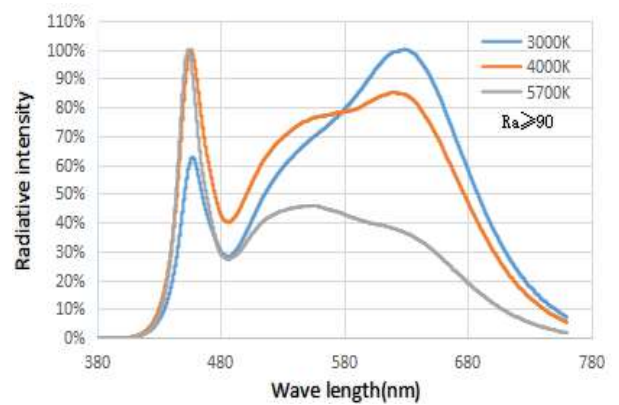
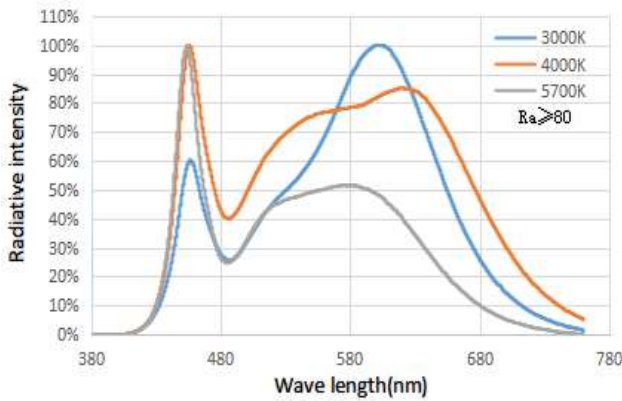

6.7 产品光分布图 Light distribution diagram

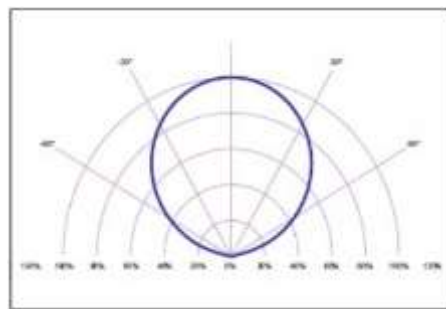
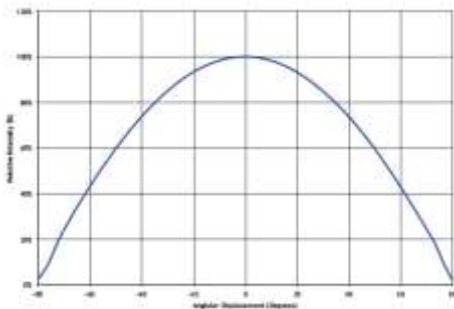

\*以上曲线图为光源特性数据，仅供参考。

➤ 分光标准 White bins on CIE-1931 ( Ta=25°C)

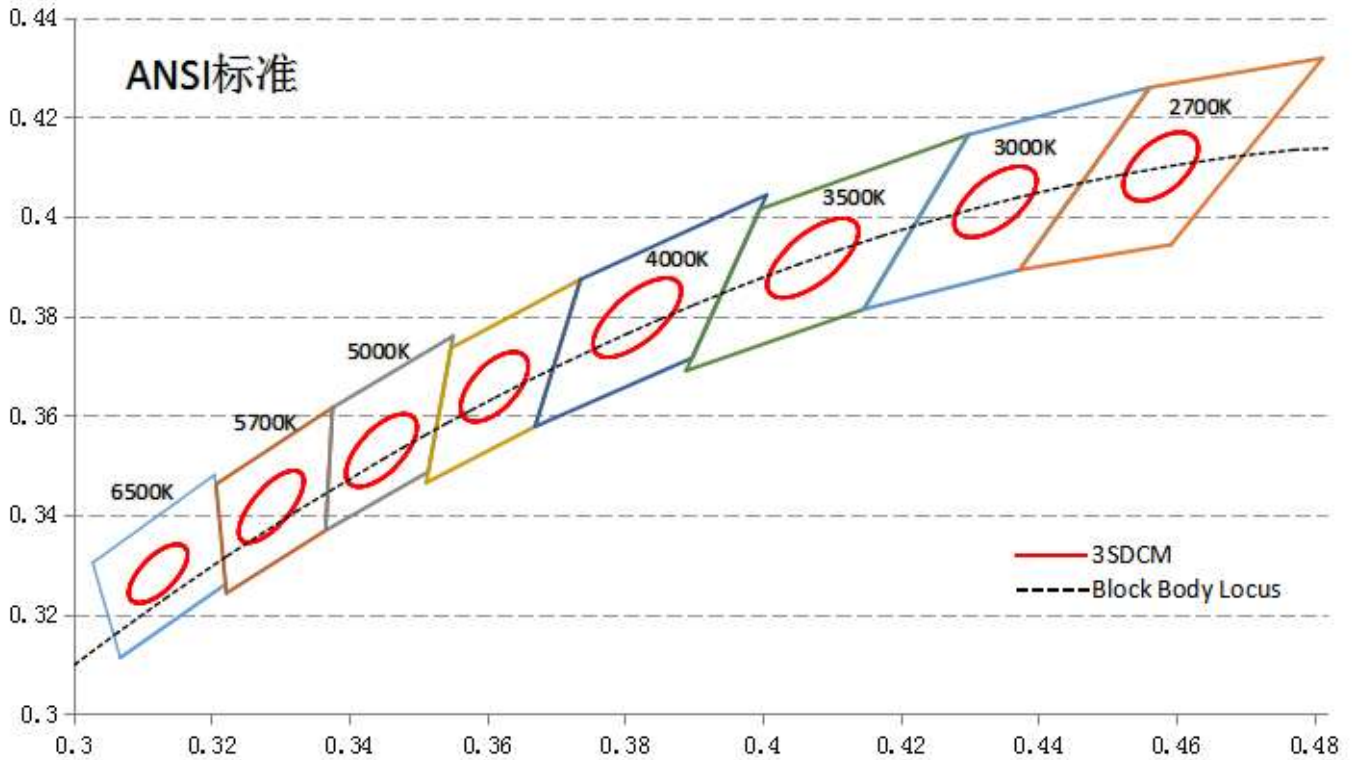

色温分 BIN Color Temperature and BIN

色温 CT	2700K	3000K	3500K	4000K	4500K	5000K	5700K	6500K
色温范围 CT Range	2660-2790	2970-3125	3350-3575	3850-4110	4350-4640	4835-5235	5440-5920	6250-6850
色温系数 CT Factor	±65	±77.5	±112.5	±130	±145	±200	±240	±300
并号 Bin NO.	L3	M3	N3	O3	P3	Q3	R3	T3

色温 CCT	色容差 chromaticity tolerances	中心点坐标 Central point coordinates		长轴 long axis a	短轴 Short axis b	旋转角度 Rotation Angle Θ
		X	Y			
2700K	3SDCM	0.4578	0.4101	0.00774	0.00411	57.28
3000K		0.4338	0.403	0.00834	0.00408	53.17
3500K		0.4073	0.3917	0.00951	0.00417	52.97
4000K		0.3818	0.3797	0.00939	0.00402	54.00
5000K		0.3447	0.3553	0.00822	0.00354	59.62
5700K		0.3287	0.3417	0.0081	0.003	61.00
6500K		0.3123	0.3282	0.00669	0.00285	58.38

\*产品按标准电流分色测试，若使用其他电流工作，光色会发生变化。

\*客户如使用 IEC 标准，请下单前提前说明，我司会及时调整标准以满足贵司要求。

Product color sorting test according to standard current, if using with other current, light/color will change.

If customers need specific IEC standards, please let us know before placing an order. We will adjust the standards to meet your special requirements.

<http://www.evercorecob.com>

TEL: 0757-86687986

FAX: 0757-81206361

地址：广东省佛山市南海区桂城瀚天科技城 A 区 3 号楼 404 单元

4F, Bldg. 3, Area A, Hantian Science & Technology Park, Nanhai

District, Foshan City, Guangdong

## ➤ 包装说明 Package and label illustration

1) 包装方式: 吸塑盒+静电袋真空包装+外箱

COB Packing : Tray + Anti-static bag with vacuum packing + outer boxes

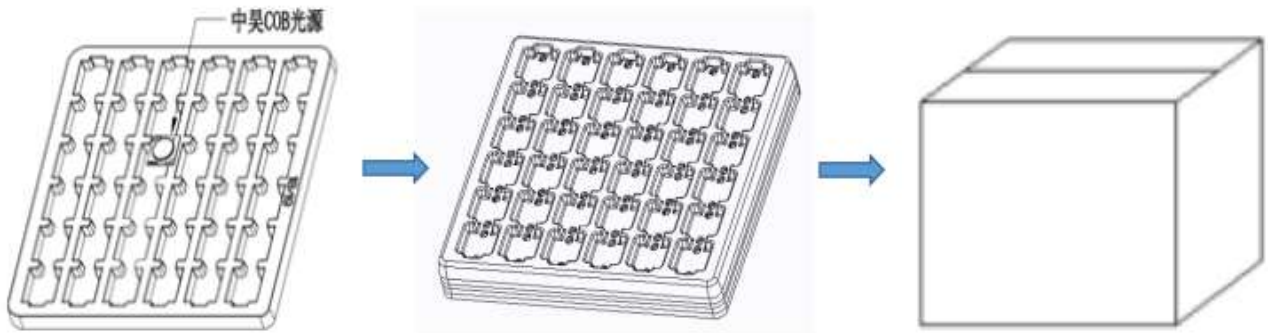

Plastic Tray

Vacuum bag packing

Outer Boxes

2) 外箱规格尺寸 Box dimensions

外箱规格 Box Size	长 Length (cm)	宽 Width (cm)	高 Height (cm)
大箱 Big	38.5	38.5	23
中箱 Medium	33	23	19

3) COB 产品包装数量说明

产品型号 PN base	片/盒 PCS/BOX	盒/包 Tray/bag	片/包 Pcs/bag	包/片/大箱 Bag/ pcs Big box	包/片/中箱 bag/Pcs/Medium box
BH1375/BH1311	36	5	180	24/4320	10/1800
BH1675/BH16105	49	5	245	30/7350	13/3185
BH1814/BH1816/BH1917	25	5	125	24/3000	10/1250
BH2321	25	5	125	26/3250	10/1250
BH28245	16	5	80	26/2080	10/800
OH3835/OH46248	9	5	45	24/1080	10/450

4) COB 产品背部喷码规则 Coding rules for the back printing of COB

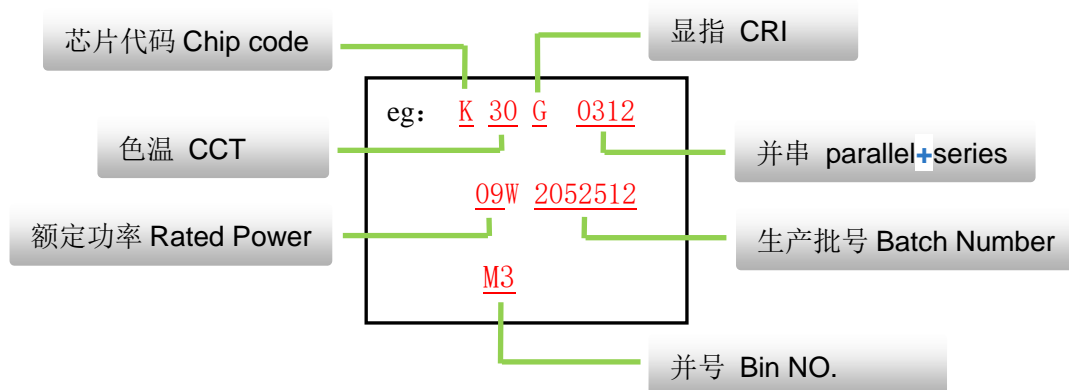

## ➤ 产品编码 Coding rules

B H13 11-03 12 J 9W 30 G-KV4X

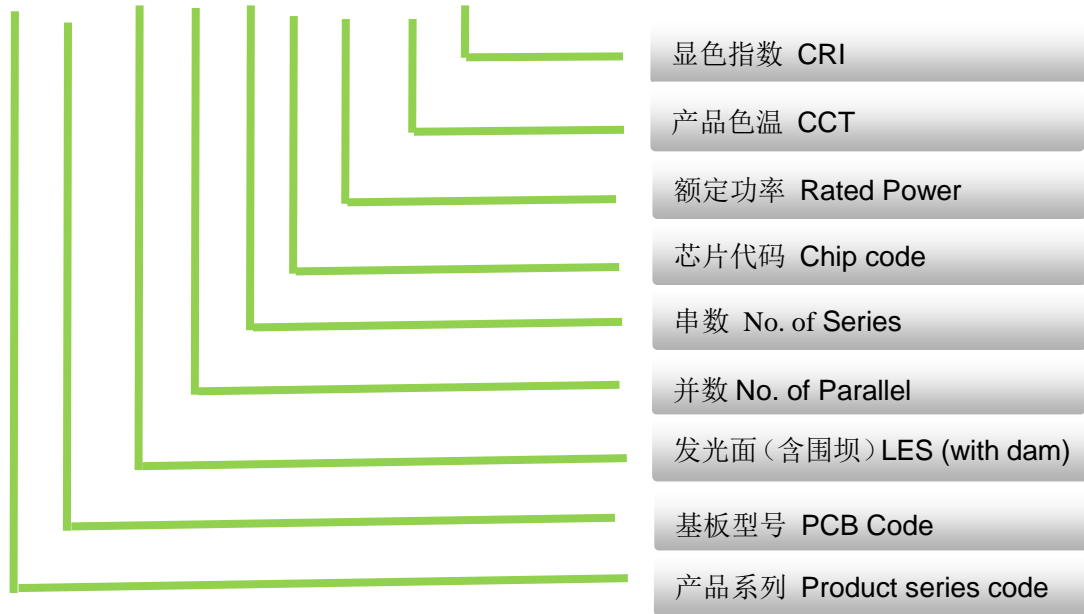

## ➤ 测试项目 Test items

类别 Type	试验项目	Test items	参考标准 standards	试验条件 Test conditions	持续时间 duration	取样数 Sample quantity	接收水准 result
环境 试验 Environment test	温度循环	Temp. cycle	JEITA ED-4701 100 105	-40℃→25℃→ 100℃→25℃ 30Min 5Min 30Min 5Min	循环 300 回合 (300 cycles)	5	0/5
	高温储存	Storage with high temp	JEITA ED-4701 200 201	Ta=100℃	168 小时/hrs	5	0/5
	低温储存	Storage with low temp	JEITA ED-4701 200 202	Ta=-40℃	168 小时 hrs	5	0/5
寿命 试验 Life test	常温寿命 试验	room temp	-	Ta=25℃ @If	1000/3000/600 0 小时/hrs	1	0/1
	高温寿命 试验	high temp	-	Ta=85℃ @If	1000 小时/hrs	1	0/1
	高温高湿 寿命试验	high temp and high humidity	-	Ta=85℃ Rh=85% @If	1000 小时/hrs	1	0/1
	大电流常温 寿命测试	High power with Room Temp	-	@1.5*If	720 小时/hrs	1	0/1
	开关实验	Soldering resistance	IEC62717	@If Tc=85℃ 30s on/30s off	30000cycle	2	0/2



## ➤ 注意事项 Announcements

### 1) 储存条件 Storage condition

储存环境湿度<60%，温度保持在 20℃-30℃，已开封 COB 光源请在 168H 内安装完毕，如未能及时使用完，请抽真空后密封保存，密封保存后有效使用期为 1 年；

The storage environment humidity is <60%, the temperature is maintained at 20℃-30℃. Once the COB light sources have been unsealed, please install them within 168H; if it is not used up within 168H, please vacuum it and keep it sealed. After sealing, the effective use period is 1 year.

### 2) 使用注意事项 Application notice

焊接时，烙铁应正确接地，手工焊接时，烙铁的温度必须低于 350℃，一次焊接时间不超过 3 秒，冷却至室温后才能再次焊接，焊接时请注意不可有外力作用于胶体表面及围坝胶上（如压力，摩擦或锋利金属钉等），以免造成金线变形或断线等异常。

When welding, the soldering iron should be properly grounded. When manual welding, the temperature of the iron must be lower than 350℃, welding time shall not exceed 3 seconds and shall be cooled to room temperature before welding again. When welding, no external force should be put on the colloidal surface and the surrounding dam glue (such as pressure, friction or sharp metal nails, etc.) or it will cause deformation of gold wire or broken wire...

为确保在组装时降低接触热阻，请注意导热膏涂布均匀且分布面积合理，不可出现导热膏太少或涂抹高低不平等现象。如使用导热胶垫时，请确保螺丝安装后基板与导热胶垫的完全接触，不可存在中空现象。

In order to reduce the contact thermal resistance during assembling, please note that the thermal conductivity paste coating is uniform with proper distribution area, too little thermal conductivity paste or uneven application level is not okay. When using thermal conductive rubber pad, make sure that the base plate and thermal conductive rubber pad are in complete contact after screw installation, No hollow space is allowed.

焊接后请不要让导热硅脂、油等接触到发光面，污垢可用气枪去除，不可用含硫、氯元素液体或洗板水等进行清洗。气枪压力：0.5MPa，时间 1 - 2 秒，距离：隔开 20cm 以上。

After welding, please do not let the heat conduction silicon grease, oil... to the luminous surface, dirt can be removed with an air gun, do not use sulfur, chlorine element liquid or washing board water to clean, Air gun pressure: 0.5mpa, time 1-2 seconds, distance: more than 20cm apart.

### 3) 静电防护 Electrostatic protection

本产品对静电敏感，所以在使用本产品时必须采取有效的防护措施，能有效的防止静电和电涌对 LED 光源的损害，当静电产生的高压电流超过 LED 光源的最大额定值时，会导致 LED 光源的损坏，甚至完全失效。客户使用产品时，应采取有效的防止静电和电涌的对应措施。建议接地电阻  $\leq 10\Omega$ ；

This product is sensitive to static electricity, so effective protective measures must be taken when using this product to effectively prevent the damage of LED light source from static electricity and surge. When the high voltage current generated by static electricity exceeds the maximum rating of LED light source, the LED light source will be damaged or even completely invalid. Therefore, Customers should take effective measures to prevent static electricity and surge when using the products. Suggested grounding resistance is  $10\Omega$  or less.

#### 4) 过温过流保护 Over-temperature, over current protection

任何时候严禁按压发光胶体部分，以免光源表面不良甚至失效。建议整灯设计时有接地电路。  
Do not press the luminous silicon surface at any time to avoid bad effect or even ineffective to the COB. It is recommended to design grounding circuit for the whole lamp design.

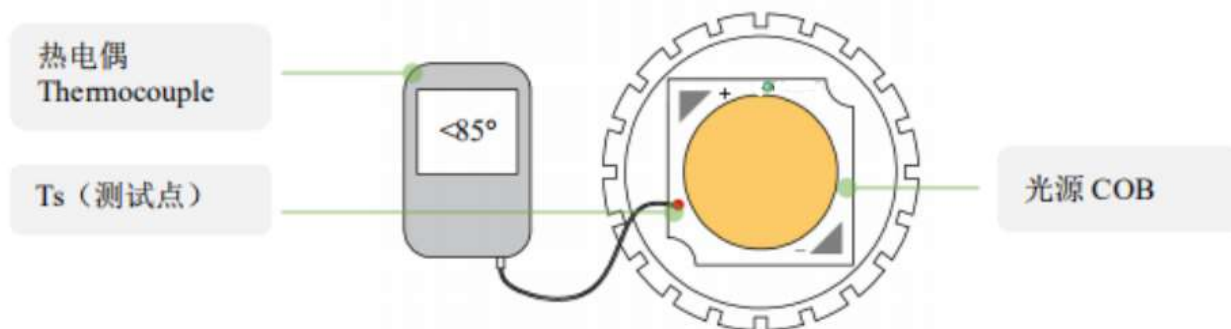

LED 光源使用湿度在 50%~80%之间，工作环境在-10℃~85℃中使用，否则会有静电击穿和大电流冲击隐患。使用本产品时请保证在规格书注明的最大额定值（最大电流及 Tc 和胶面温度）内使用，如未遵守产品规格书的最大额定值及说明而产生的不良后果，不在中昊承诺质保范围之内。

The working humidity is between 50% and 80%, and the working environment is between -10°C and 85°C, otherwise, there will be hidden dangers of electrostatic breakdown and large current impact. When using this product, please ensure that it is used within the maximum rating (maximum current and Tc and glue surface temperature) specified in this specification. Any adverse consequences arising from failure to comply with the maximum rating and description of the product specifications shall not be covered by the warranty.

#### 5) 散热设计 Thermal design

LED 光源的良好运行取决于 LED 光源热阻、外部导热热阻、功率损耗和环境温度。  
LED 结温过高将影响光通量和光源寿命。在散热设计时应充分考虑这些因素。

A good use effect of LED light source depends on the thermal resistance of LED light source, external thermal resistance, power loss and ambient temperature.

High junction temperature of LED will affect the light flux and the working life of the light source. Full consideration of these factors is highly recommended in heat dissipation design.